

**PLAN**

OPTIONAL EXTENSION:  
 30"Ø X 1/4" THK X (12",  
 24", 30", 36", 60", 72",  
 84") HEIGHT  
 Ø30" X 1/4" THK COLLAR

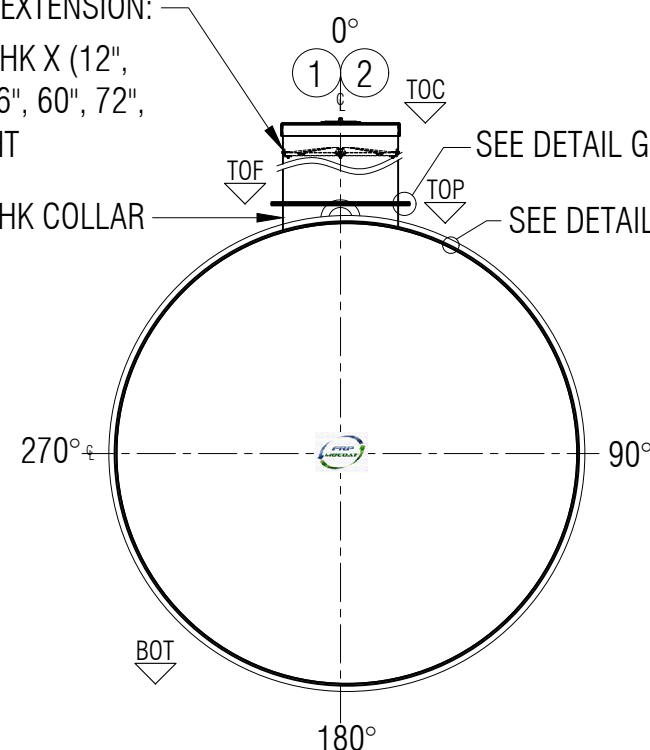

**ELEVATION B**

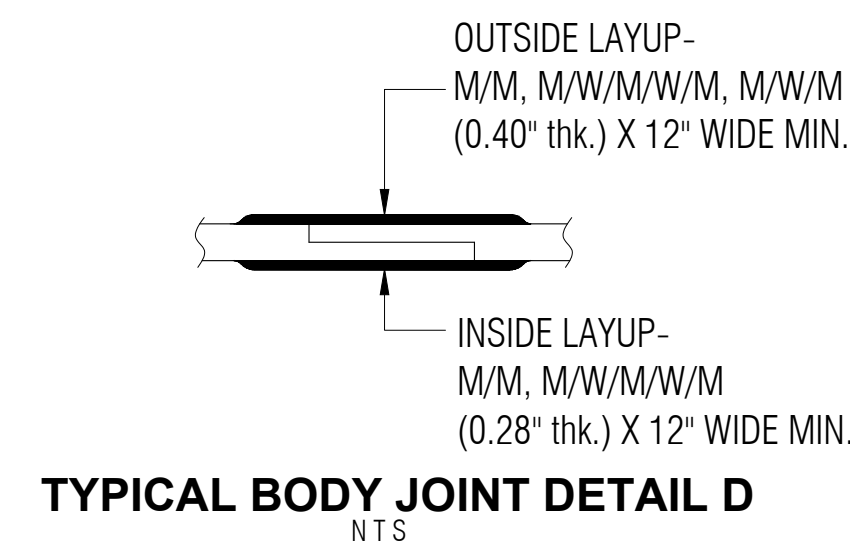

**TYPICAL BODY JOINT DETAIL D**  
NTS

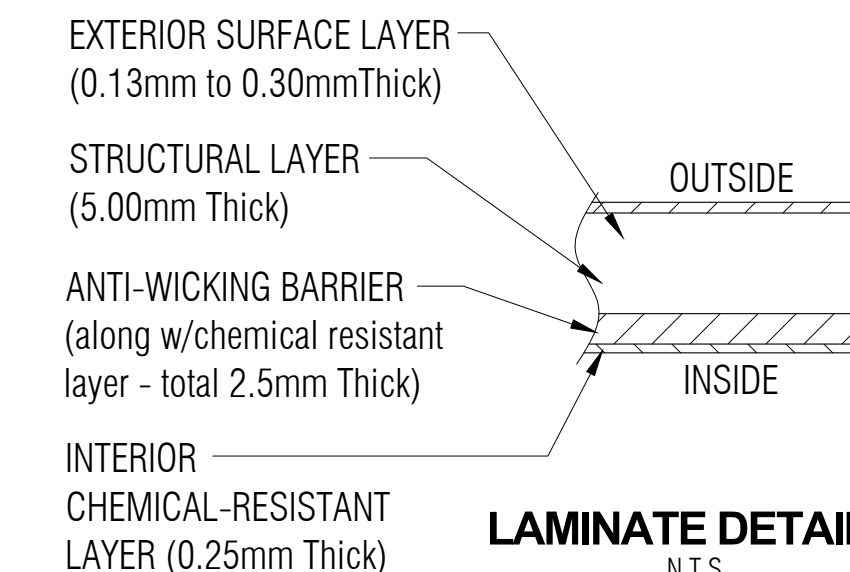

**LAMINATE DETAIL E**  
NTS

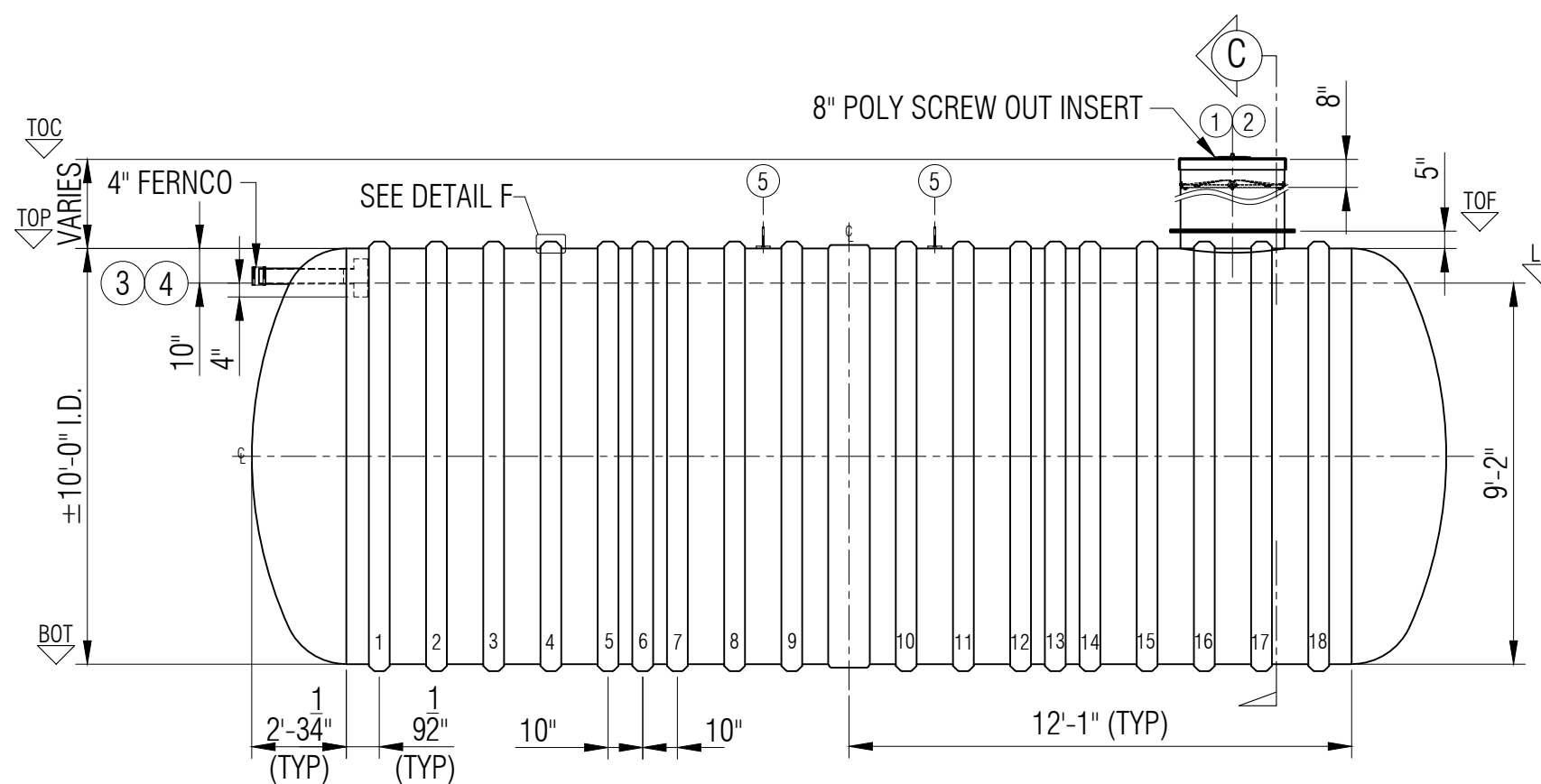

**ELEVATION A**

Ø30" X 1/4" THK FRP LID  
 30"Ø SAFETY GRATE  
 SEE DETAIL H  
 30"Ø COLLAR BONDED  
 TO TANK

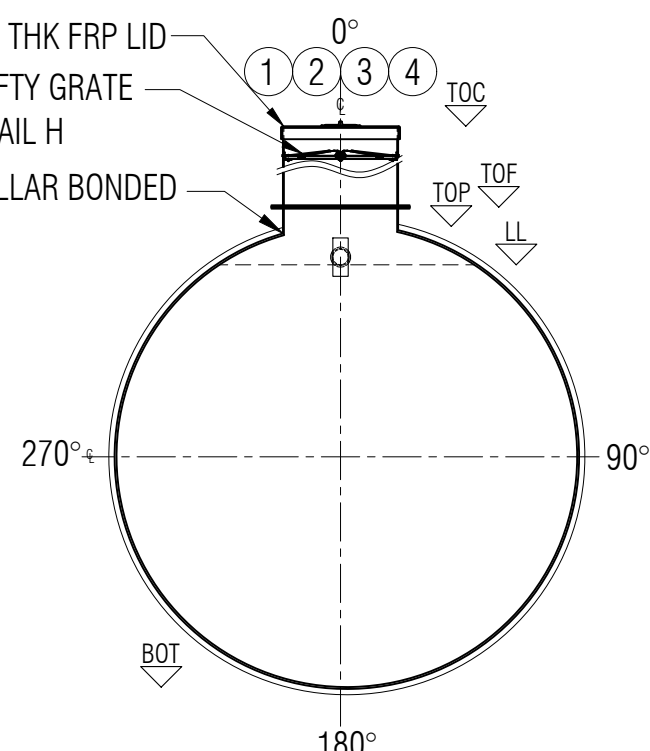

**SECTION C**

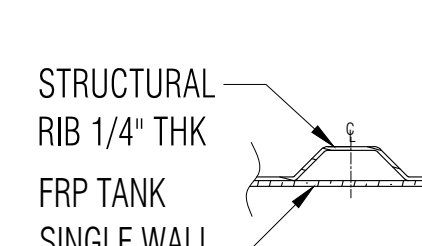

**RIB LAMINATE DETAIL F**  
NTS

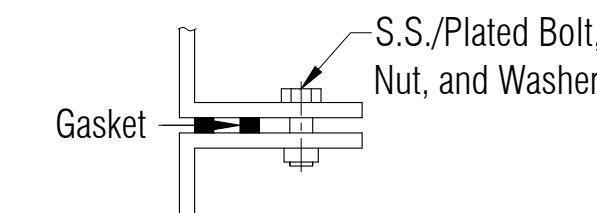

**FLANGE TO FLANGE CONNECTION DETAIL G**  
NTS

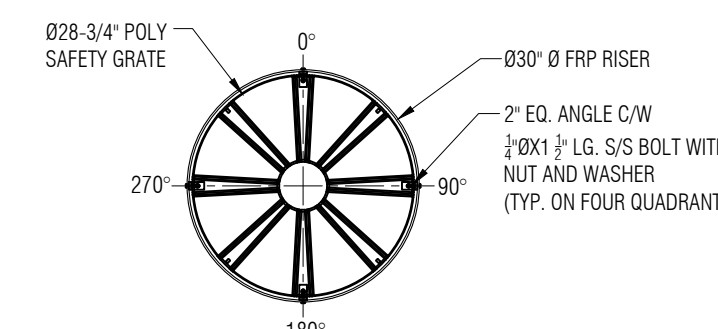

**SAFETY GRATE DETAIL H**  
SCALE: 1:20

LEGEND:  
 TOC - TOP OF CAP LID  
 TOF - TOP OF FLANGE  
 TOP - TOP CYLINDER  
 BOT - BOTTOM CYLINDER  
 I/S - INSIDE  
 LL - LIQUID LEVEL  
 O.A.H.-OVERALL HEIGHT  
 O.A.L.-OVERALL LENGTH  
 I/S - INSIDE  
 O/S - OUTSIDE  
 Ø - DIAMETER  
 ° - DEGREE/S  
 TYP - TYPICAL  
 CL - CENTER LINE  
 NTS - NOT TO SCALE

GENERAL NOTES:  
 - CSA B66 CERTIFIED FRP TANK FOR WASTE WATER.  
 - RATED FOR 10' OF BURIAL DEPTH AND NO TRAFFIC LOADING.  
 - ALL DRILLED HOLES FLANGES TO BE COATED WITH RESIN.  
 - SAFETY DEVICE CAN WITHSTAND 91 KG. OF DEAD LOAD.  
 - DIMENSIONS SHOWN IN FEET INCHES FORMAT OTHERWISE NOTED.  
 - 1/2" FABRICATION TOLERANCE. DOES NOT APPLY TO LAMINATE THICKNESS.

ITEM#	QTY	PART LIST	DESCRIPTION	SHELL THICKNESS: 0.425"	DRAWN: ATF
1	1	30" CAP LID W/ 8"D POLY SCREW OUT INSERT	FPR LID	DISH HEAD THICKNESS: 1.030"	CHECKED: ATF/MPS
2	1	30"Ø MANWAY COLLAR	30"Ø FRP COLLAR	RIBS THICKNESS: 0.300"+2 WR (0.066")=.366"	DATE: APR. 14, 2023
3	1	4" FERNCO	FLEXIBLE CONNECTOR	RIB SPACING: 16-1/2" (CL to CL)	DESIGNED: FRP
4	1	4"Ø PVC PIPE & TEEWYE	INLET	LENGTH: 8,750MM (28'-8 1/2")	APPROVED: MPS
5	2	MILD STEEL	LIFT LUGS	WORKING CAPACITY: 52,425L (11,532IG/13,850 USG)	MFG: DS
6	1	POLYETHYLENE SAFETY GRATE C/W HARDWARE	SAFETY GRATE	OVERALL CAPACITY: 57,157 L (12,573IG/15,100 USG)	PM: GA
				NUMBER OF RIBS: 18	SALES: TA

CLIENT: FRP/MOCOAT FIBERGLASS LTD.  
 TITLE: **BX13000-DB FIBERGLASS HOLDING TANK**

**FRP MOCOAT**  
FIBERGLASS LTD.

SIZE: C	DRAWING NUMBER: BX13000-DB	REVISION: 0
SCALE: 1:50	WEIGHT:	SHEET: 1/1
BURIAL DEPTH:	RATED 10'-0"	