

LABEL LOCATIONS					
ITEM	QTY	DESCRIPTION	ITEM	QTY	DESCRIPTION
A	1	NAME PLATE	B	1	INLET
C	1	OUTLET	D	1	DANGER GAS
E	2	LIFTING HANDLE			

* TANK COMES FULLY ASSEMBLED FROM FACTORY *

* PVC FITTINGS ARE CSA CERTIFIED

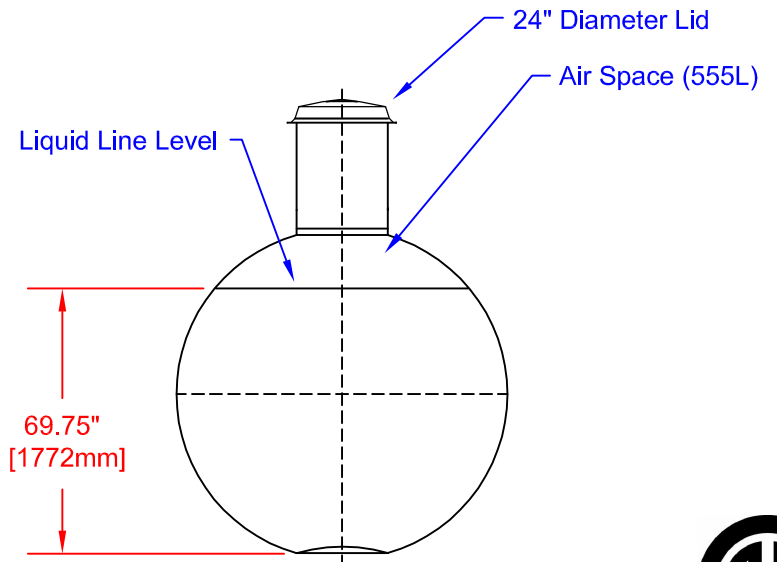
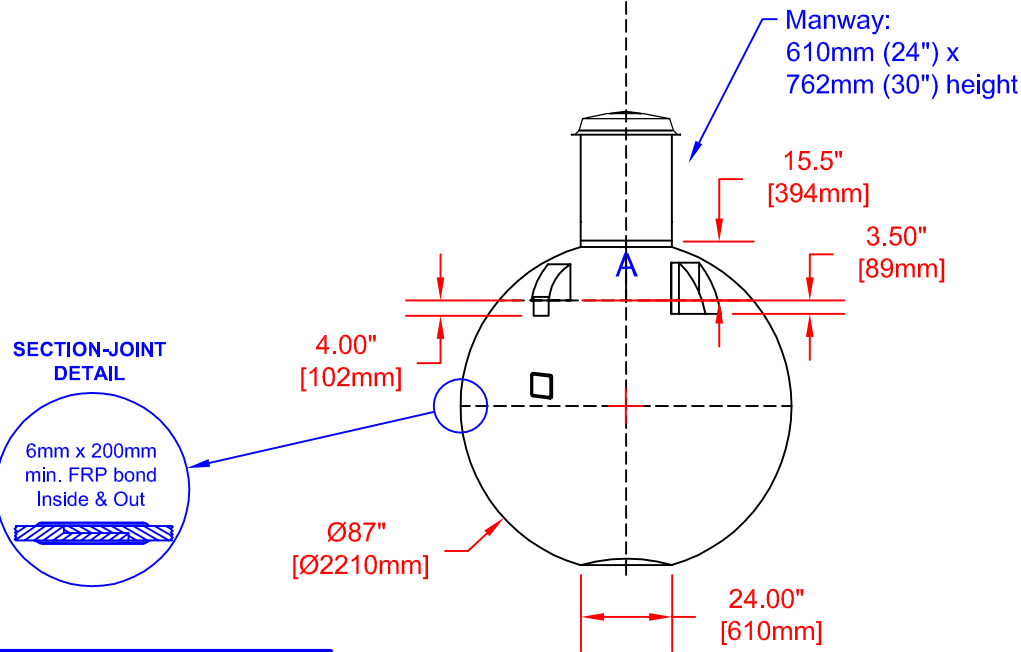
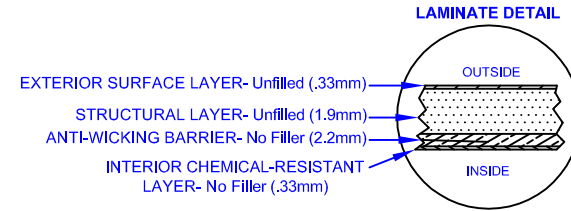
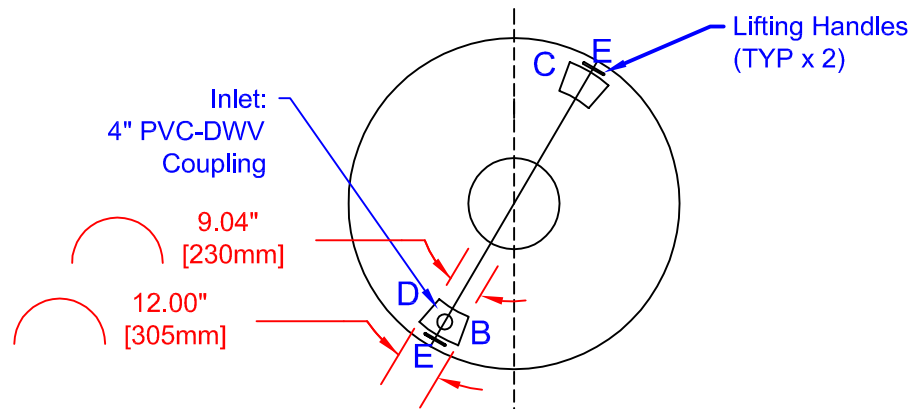

FRP
MANUFACTURING (2010) INC.
www.frpmtg.com
1-866-722-6246

**HB1100 FIBREGLASS
SEWAGE HOLDING TANK**

Overall Diameter:	2,210mm (87")	Overall Weight:	182kg (400lbs)		
DATE:	05-25-2007	DATE:		DWG SCALE:	Nominal Capacity: 5,655L (1,244 Imp Gal, 1,493 US Gal)
BY:	MARK SOLLID	APPROVAL:		REV:	A
					Holding Capacity: 5,100L (1,122 Imp Gal, 1,346 US Gal)